

Installation Guide

Celona Indoor Access Point AP 22

Enabling cellular wireless connectivity for enterprise environments, within private spectrum options



celona

© Copyright 2023 Celona Inc. All rights reserved.

Contents

Introduction 3

About the AP	3	Power input	3
Package Contents	3	GPS	3
Ethernet ports	3	Status LEDs and Interfaces	3

Mounting 4

Installation Overview	4	Install on silhouette and interlude T-bar	7
Mounting the Access Point	4	Install on wall	10
Install on Prelude and Suprafine T-bar	5		

Powering the Access Point 12

Access Point Discovery and Provisioning	12	Configuring the Access Point	12
---	----	------------------------------	----

Solution Architecture 13

Celona AP 22 capabilities	13
---------------------------	----

Operations and Maintenance 14

Security	14	Supported frequency band	15
Phase and time synchronization	14	Seamless session mobility	15
Data and voice connectivity	14	Coverage area	15
Power save mode	14	Transmit power	15
Radio access technology	15	Supported system bandwidth	15

Troubleshooting 16

Contacting Support	16	Warranty	16
--------------------	----	----------	----

Introduction

This document provides the necessary guidance to help the user enable services on the Celona Indoor Access Point AP 22 capable of private 5G connectivity.

About the AP

Celona AP 22 is an indoor 5G NR access point as a part of Celona's 5G LAN solution portfolio, supporting Sub-6 GHz frequency bands (3.3–4.2 GHz). AP 22 offers highly deterministic performance over the air including up to 1 Gbps aggregate throughput, less than 10ms latency and exceptional coverage. With an enterprise-ready operational model, Celona AP 22 access point is designed for mission-critical use cases in indoor and semi-ruggedized environments. Like all Celona access points, the AP 22 supports plug-and-play deployment, remote provisioning, centralized cloud-based management, and seamlessly integrates into the enterprise network.

Celona AP 22 is 3GPP Release 15 compliant 5G NR access point that supports 2x2 MIMO, up to 256 QAM modulation, subcarrier space of 30 KHz and can be ceiling or wall mounted.

Package Contents

Verify that you have received the items below. If any item is missing or damaged, contact your Celona partner or reseller for instructions.

- The Access Point
- Mounting bracket and screws
- PoE++ injector

Ethernet ports

The Celona AP 22 has 1/2.5 Gigabit Ethernet port.

Power input

Celona AP 22 supports IEEE 802.3bt Type 3 (PoE++) connectivity. PoE++ can be provided by a PoE++ injector (AC to PoE power, included in the AP) or a PoE++ capable switch. The drawn power is ≤ 51 W.

GPS

A Subminiature Version A (SMA) coaxial RF connector port is available for GPS. If obtaining GPS lock is difficult, connecting a GPS puck to the Celona AP 22 may help achieve lock. The GPS puck is typically placed closer to a window where there is line of sight visibility to the sky and a cable is extended from the GPS puck to the SMA connector port for GPS on the Celona AP 22.

Status LEDs and Interfaces

The Celona AP 22 has 2 LEDs providing the following visual statuses for System, 5G

Identity	Color	Status	Description
System	Blue	Steady on	Power is on
		OFF	No power supply
5G	Blue	Steady on	Radios are up and transmitting
		OFF	Radios are non-operational

Mounting

Installation Overview

The Celona AP 22 can be wall or ceiling mounted and has two omnidirectional internal antennas. Internal antennas are down-tilt toward the front of the AP. Before you mount and deploy your access point, we recommend that you perform a wireless design to determine the best location to install your access point.

The AP requires an operational Celona Edge for discovery and network service. Celona recommends installation and deployment of the Celona Edge prior to installation of access points. Have the following information about your wireless network design available:

- Locations for access point installation
- Mounting requirements for each location: suspended from a drop-ceiling, surface mount on a hard ceiling, or on a flat horizontal surface

Installing the access point involves the following steps:

1. Mounting the Access Point
2. Powering the Access Point
3. Access Point Discovery and Provisioning
4. Configuring the Access Point

Mounting the Access Point

The Celona mount kit supports several mounting methods, including from a suspended drop-ceiling, hard surface ceiling, and flat horizontal surfaces such as a wall. The standard mounting hardware included with the AP supports these mounting methods.

Main parts of mounting kit assembly

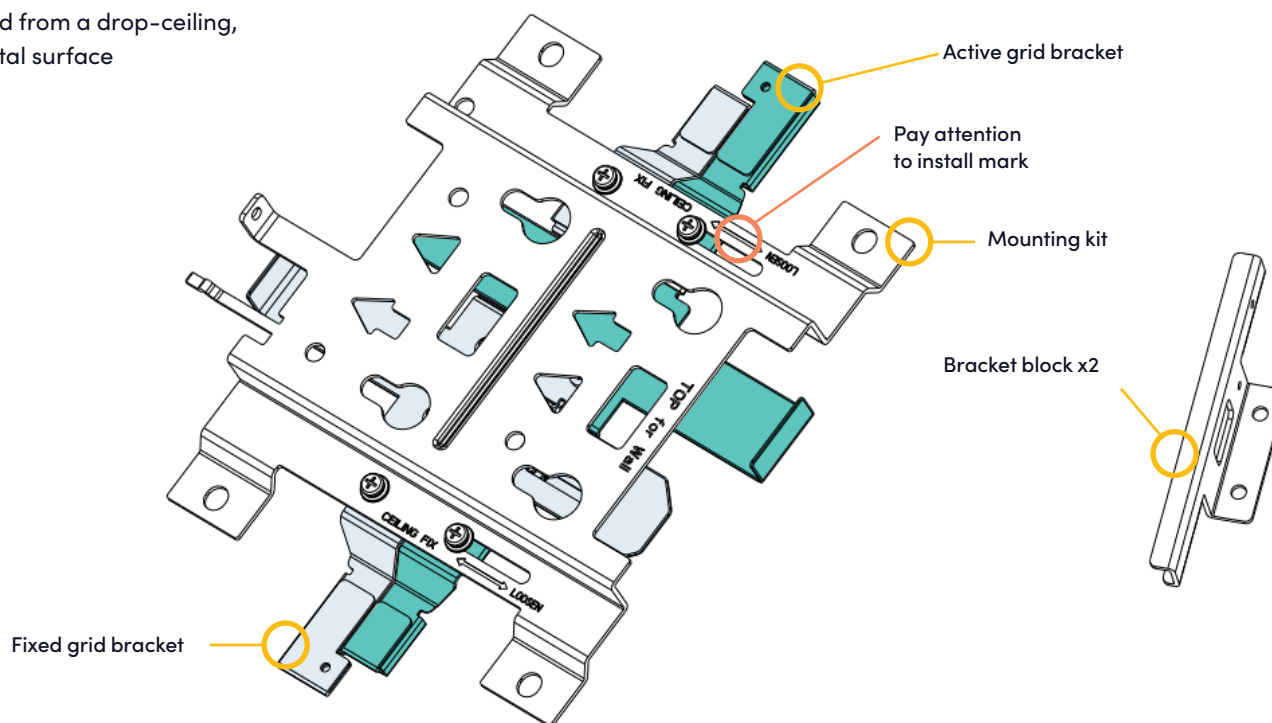

Mounting

Install on Prelude and Suprafine T-bar

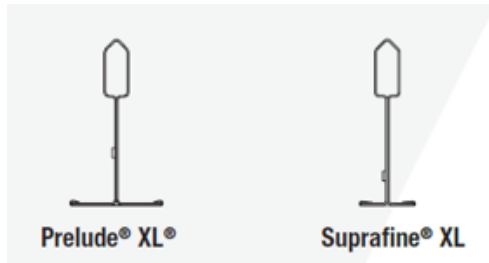

Step 1: Loosen two screws and pull out the active grid bracket.

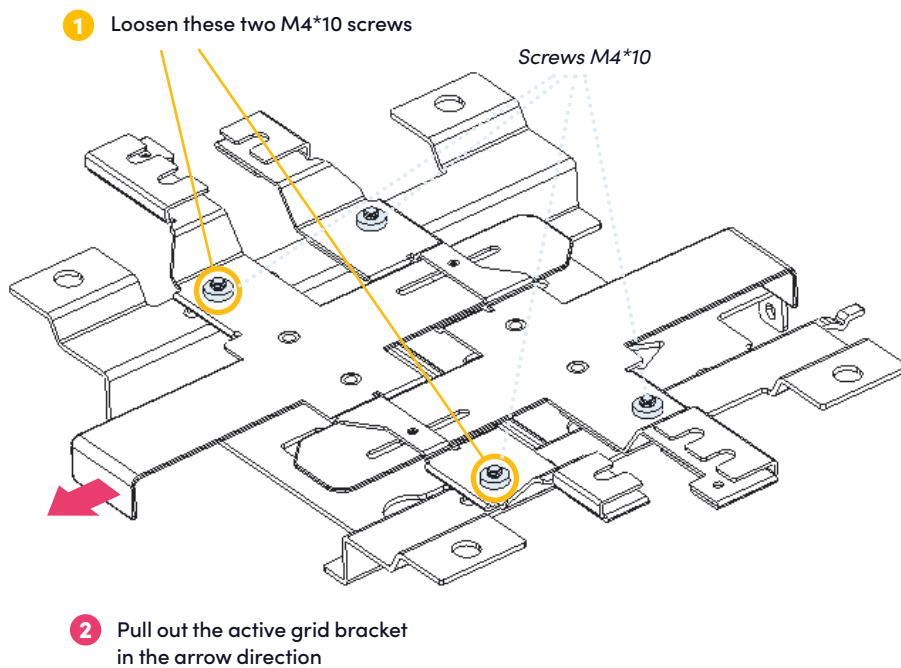

Step 2: Push the active grid bracket to hold the T-bar

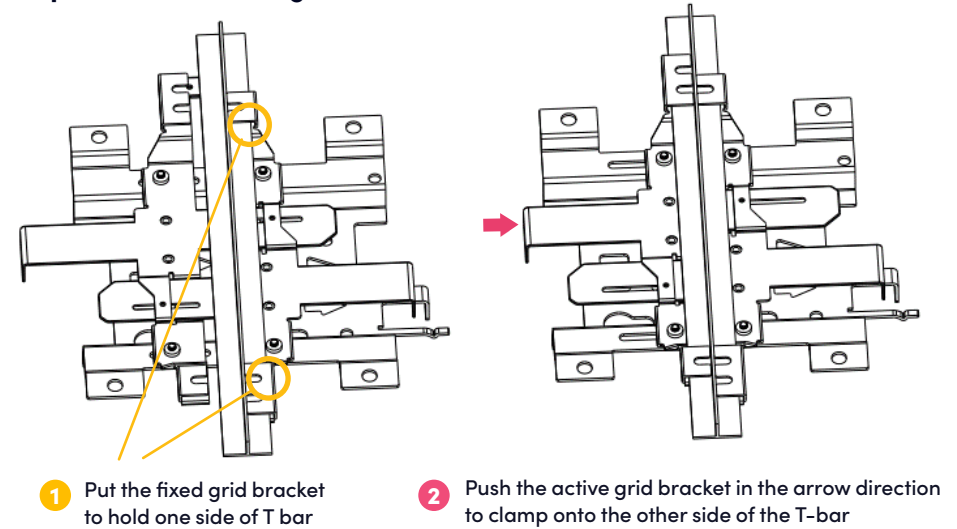

Step 3: Fix the active grid bracket and fasten the two screws to prevent the mounting kit from slipping.

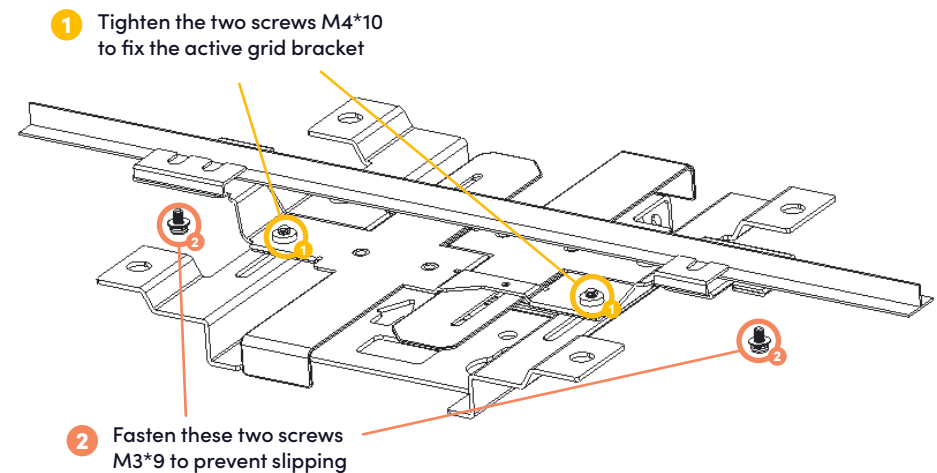

Mounting

Step 4: Slide device to mounting kit, aligning the four screws and the slot.

Before slide the device

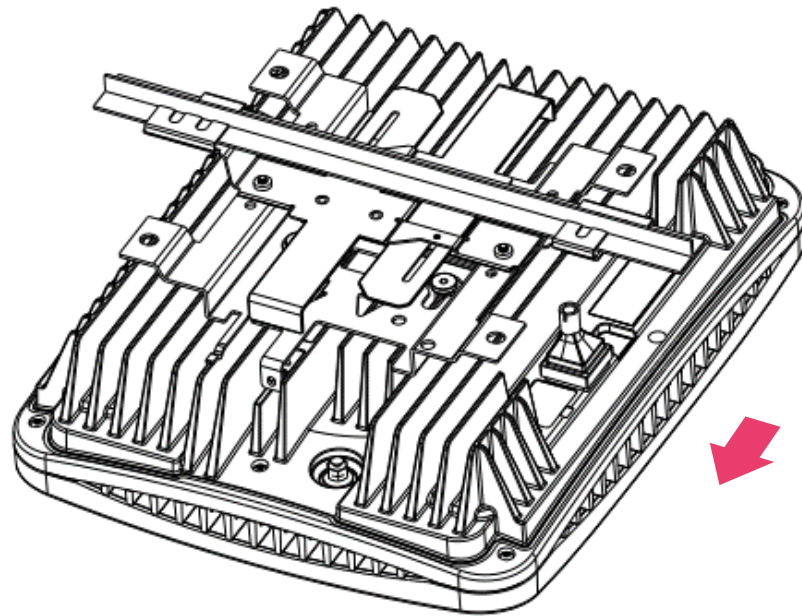

- 1 Slide device by arrow direction to hold on mounting kit.

Step 5: Fasten one M3*9 screw to fix device and mounting kit.

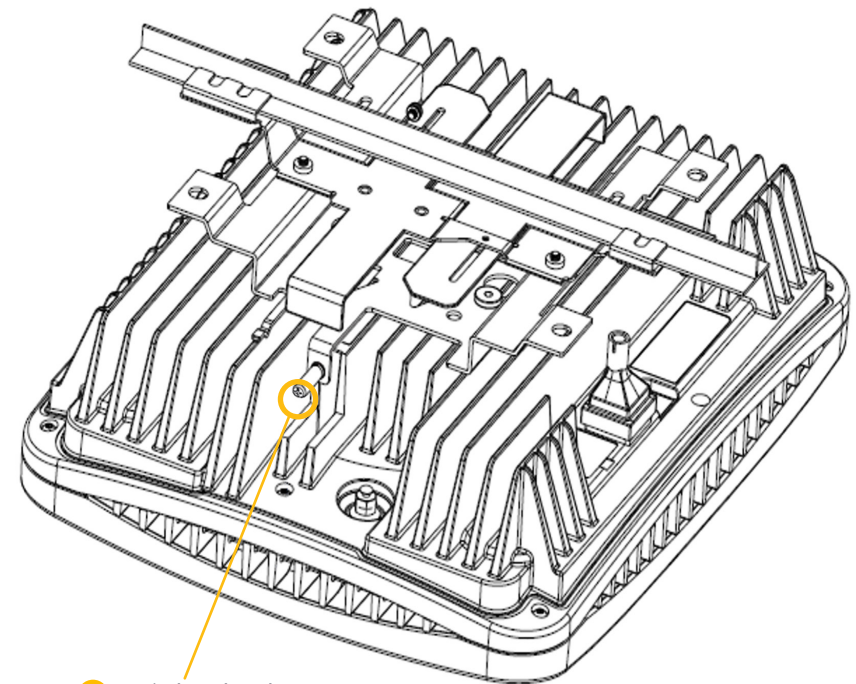

- 1 M3*9 long head screw

Mounting

Install on silhouette and interlude T-bar



Silhouette® 1/4" XL



Silhouette® 1/8" XL



Interlude® XL

Step 1: Fix two bracket blocks onto the two grid brackets.

- 1 Fasten four screws to combine the two bracket blocks on the grid bracket

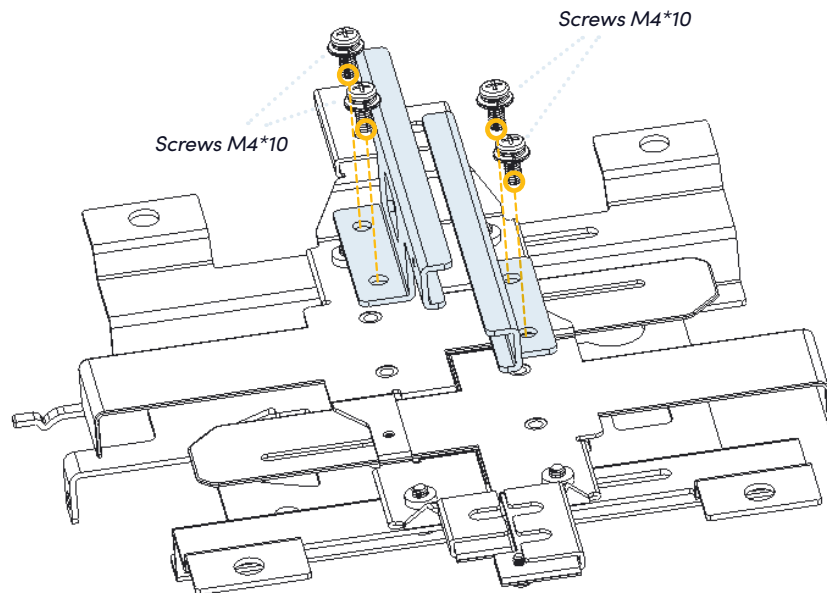

Step 2: Loosen two screws and pull out the active grid bracket.

- 1 Loosen these two M4*10 screws

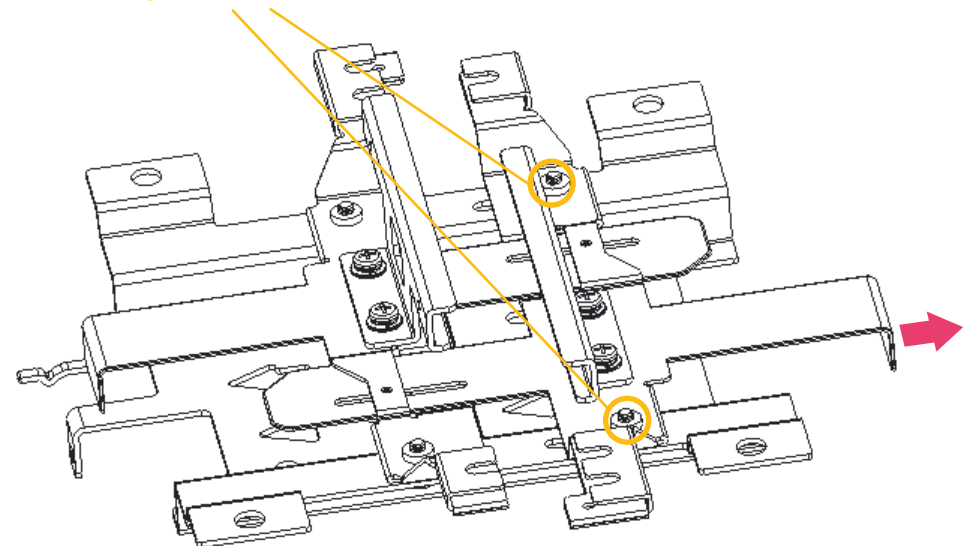

- 2 Pull out the active grid bracket in the direction of the arrow

Mounting

Step 3: Push the active grid bracket to the T-bar.

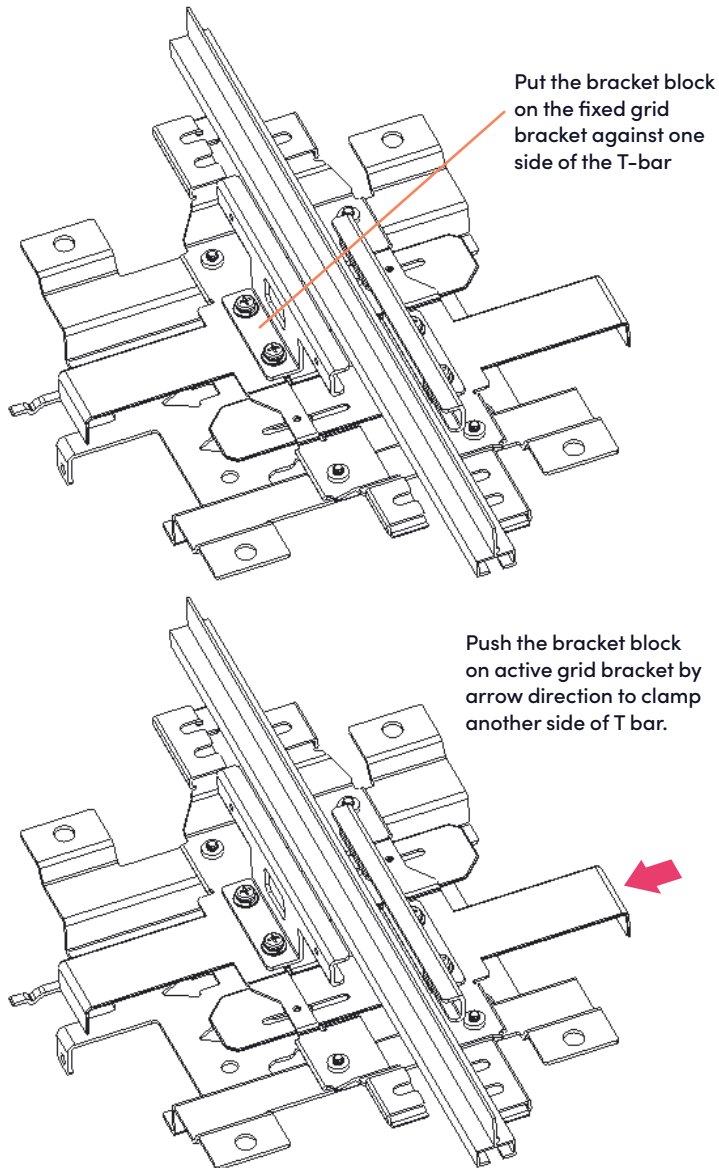

Step 4: Fix the active grid bracket and fasten two screw to prevent mounting kit from slipping

1 Fasten these two screws M4*10 to secure the active grid bracket

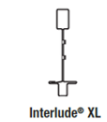
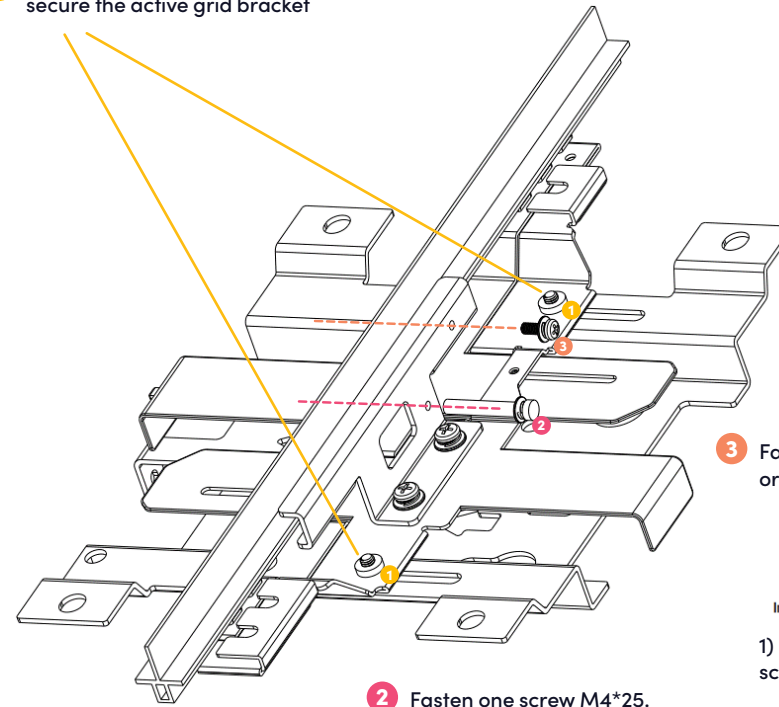

1) Interlude® XL T bar: use screw M3*9;



2) Silhouette® 1/4 and 1/8 XL T bar: use screw M3*6.

Mounting

Step 5: Slide device to mounting kit, aligning the four screws and the slot.

Before slide the device

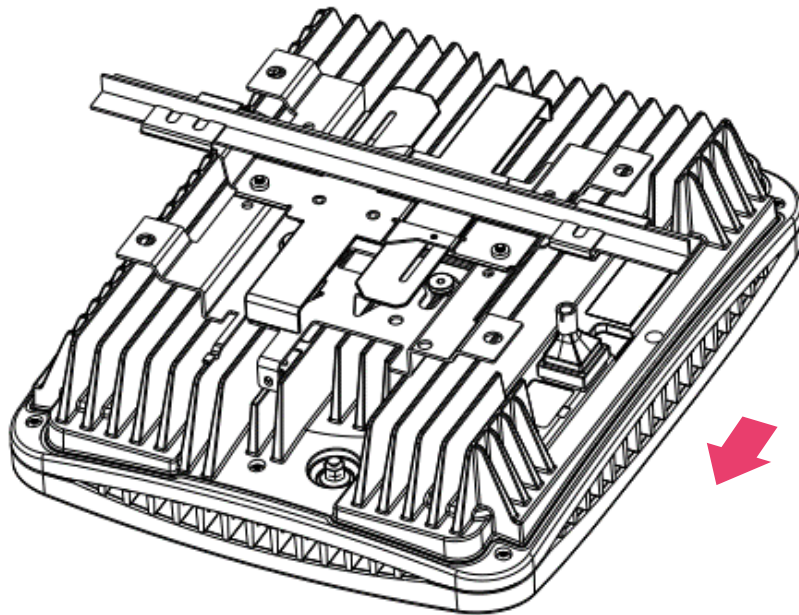

- 1 Slide device by arrow direction to hold on mounting kit.

Step 6: Fasten one M3*9 screw to fix device and mounting kit.

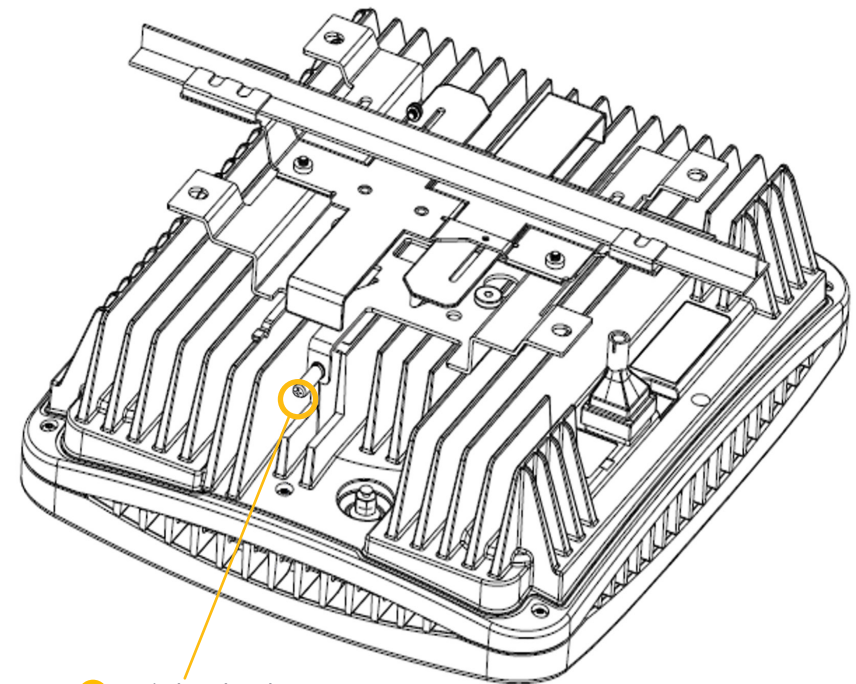

- 1 M3*9 long head screw

Mounting

Install Anti-Rope

Step 1: Pull out the short side of rope from the lock head.

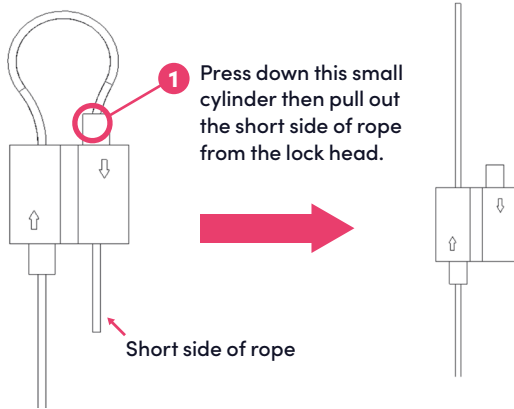

Step 2: Loop the rope around the T-bar.

- 1 Put the short side of rope across the T-bar from top side.
- 2 Insert the rope into the lock head by arrow direction.

Notes: The rope length can be adjusted,

1) Along the arrow direction the rope length can be adjusted freely;

2) By pressing these two small cylinders on the lock head, the rope length can be adjusted on the other direction.

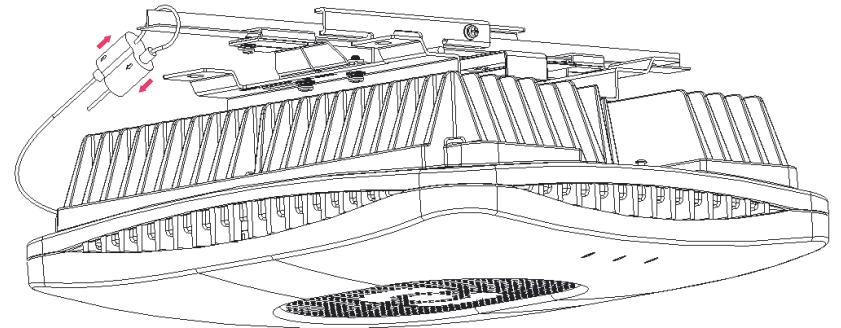

Step 3: Tighten the rope and device by screw M5*8.

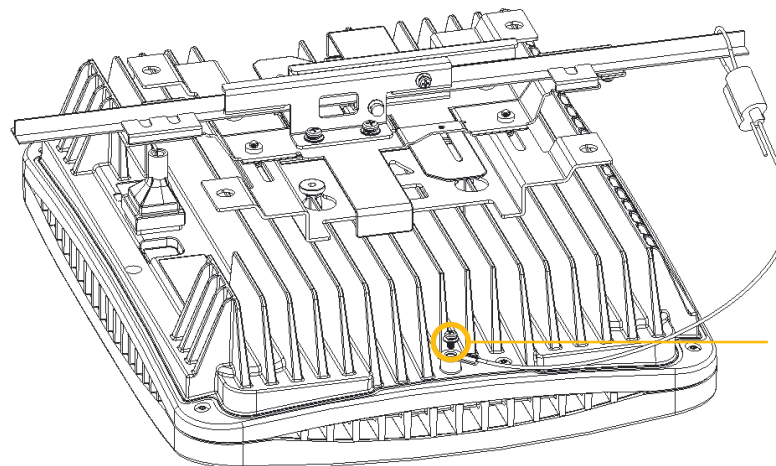

M5*8 screw go through the hole on spacer and tighten to the device.

Mounting

Install on a wall

Step 1: Disassemble two grid brackets from the mounting kit.

1 Loosen these four M4*10 screws, then remove the two grid brackets

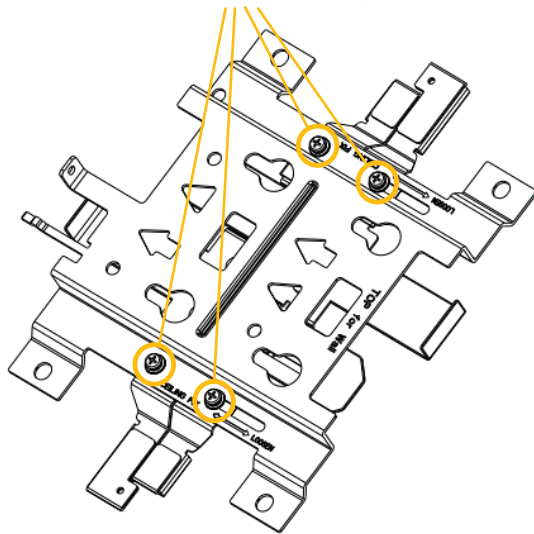

Only the mounting kit will be used for wall mounting

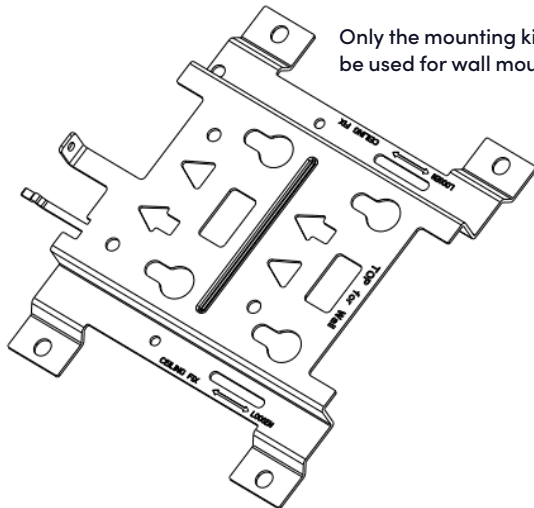

Step 2: Drill four holes on the wall using bit size Φ 8.00mm. See below of the distances.

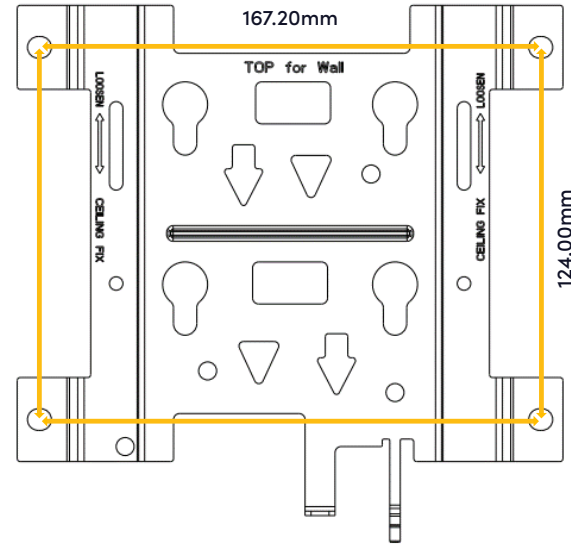

Hole distance: 167.20*124.00mm
Hole depth: 40.00mm

Step 3: Insert the four expansion screws into holes.

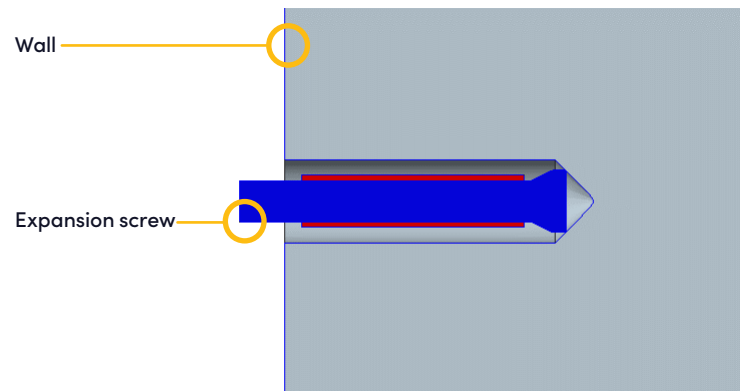

Mounting

Step 4: Place the mounting kit to the wall and fasten the four nuts.

1 Fasten four M6 nuts with torque: 35kgf/cm

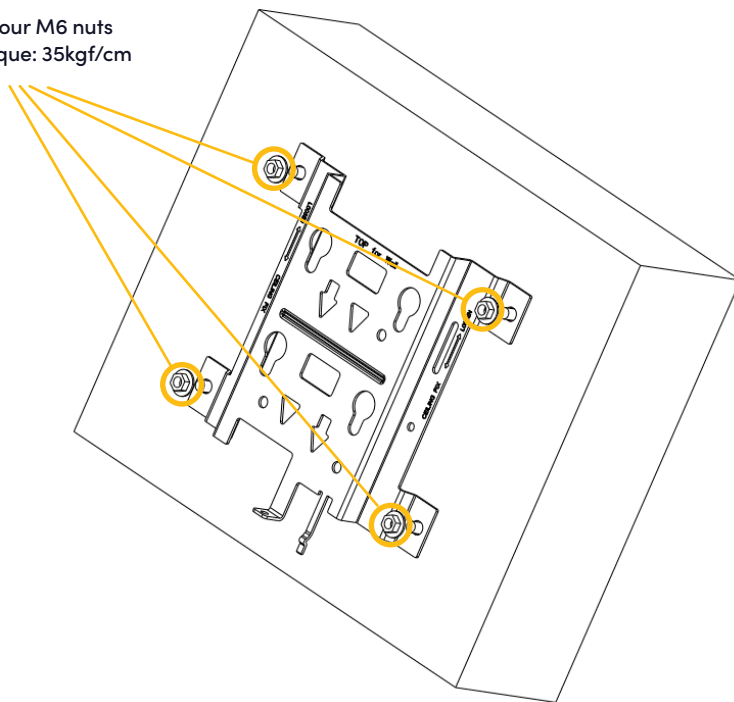

Step 5: Slide the device to attach to the mounting kit.

1 Align the four screws on the device to the mounting kit slots

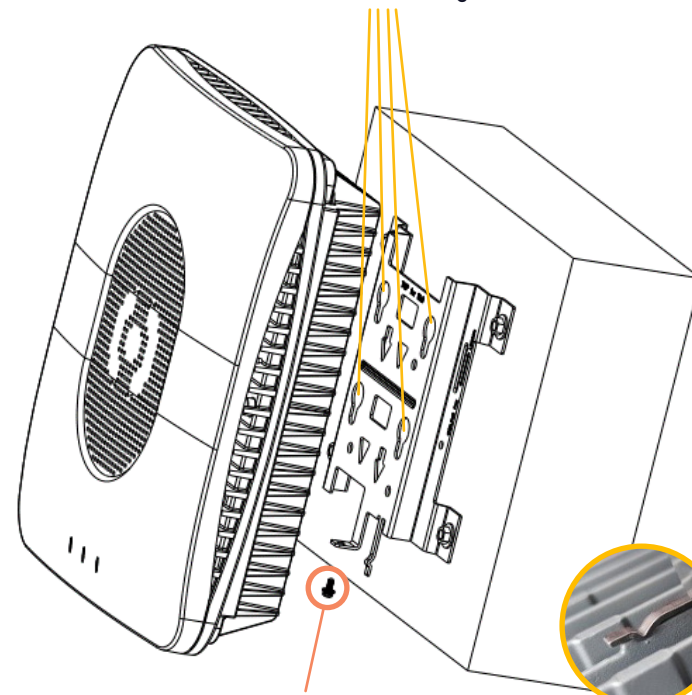

3 Fasten screw M3*9.

2 Slide the device down until the spring hook on the mounting kit meets the groove of the device

Powering the Access Point

The Celona AP 22 can be powered by IEEE 802.11bt (POE++) on the WAN Ethernet port or connected to an AC electrical outlet using the optional AC power injector/adaptor.

Access Point Discovery and Provisioning

The AP will connect to the Celona Orchestrator for provisioning and discover the Celona Edge within the network on-premises or in the private/public cloud based on the site assignment. The AP will then connect directly to the Celona Edge and establish control and data plane connections. Once this is completed, the 5G LED on the AP will turn blue, signifying the private 5G network is operational. This will take approximately 2-3 minutes.

Configuring the Access Point

The Celona AP 22 supports zero-touch provisioning. The AP is preconfigured with details necessary to discover the Celona Orchestrator and the Celona Edge automatically. After the AP discovers the Celona Orchestrator and the Celona Edge, the AP gets provisioned with operational parameters and is authorized to transmit. The Celona Edge alone controls the radio frequency transmission of the Celona AP 22. Once the AP has gone operational, it is able to provide services to mobile stations. The mobile stations can interact with the enterprise network via the Celona Edge. The user data and control signals are encrypted. The Celona AP 22 performance is periodically monitored by the Celona Edge and operational parameters are continually optimized if necessary. Refer to the Celona Orchestrator configuration guide for detailed instructions on configuring Celona access points.

Solution Architecture

The high-level architecture that enables the Celona AP 22 is shown below.

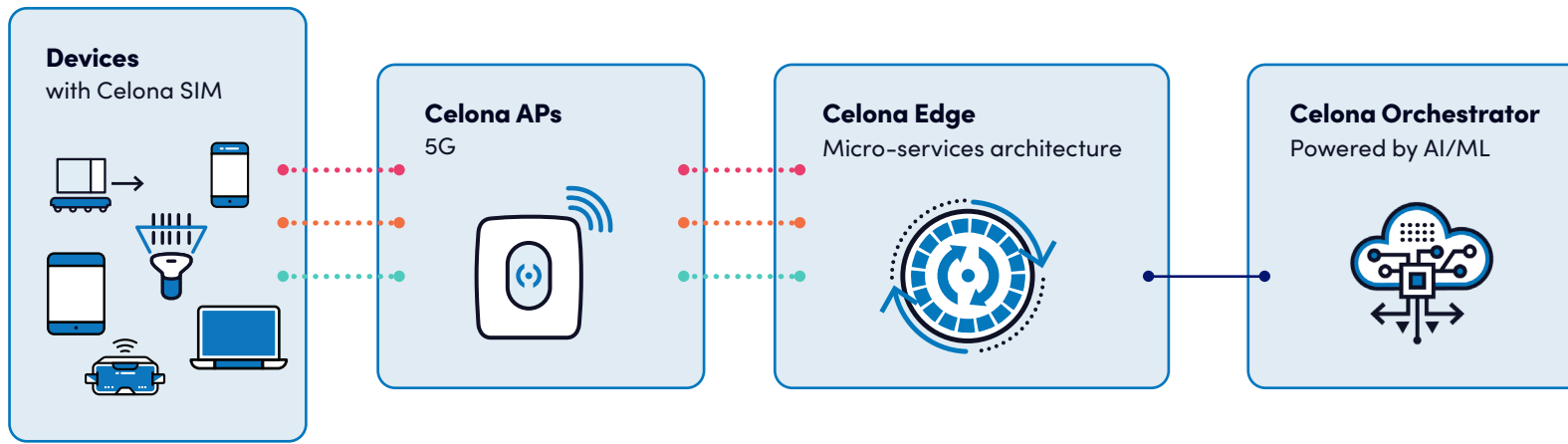

The system consists of the essential functions detailed in Figure 1: System Architecture. The Celona Orchestrator performs AP authentication, validates the AP's serial number, determines the network the AP needs to connect to and finally directs the Celona AP 22 to the serving Celona Edge.

Each Celona AP 22 obtains service via its serving Celona Edge. The Celona Edge registers the Celona AP 22, arbitrates spectrum with a FCC approved Spectrum Access Service (SAS) system in the United States (AP22-48 only) and algorithmically determines the most optimal radio parameters for the AP.

The Celona Edge becomes automatically aware of the Celona AP 22's location and its existing surrounding radio environment. Once the AP is admitted by the Celona Edge, the AP can commence radio transmissions and service the mobile stations.

Celona AP 22 capabilities

The following sections give the reader the capabilities of the Celona Indoor Access Point (AP), which is based on the Qualcomm platform. The AP hosts functions to provide the following services:

- Resource management with admission and flow control
- Encryption of user data and control streams
- Registering mobile stations with Celona Edge for connectivity services
- Paging the mobile stations that are in power save mode
- Fairness in allocation of resources across multiple stations in uplink & downlink directions
- Measurement configurations and handling of mobility of mobile stations

Operations and Maintenance

The Celona AP 22 is operationally maintained by the Celona Orchestrator and Celona Edge using NETCONF. Celona AP 22's radio parameter provisioning, performance monitoring and fault monitoring occur over the NETCONF interface. The AP supports the following technical reports from the Broadband Forum.

Celona AP 22's performance is monitored between every 5 minutes and 15 minutes based on the periodicity determined by the Celona Edge. If a fault surfaces on the AP, the fault is automatically propagated by the AP to the Celona Edge and the Celona Orchestrator.

Security

The certificates that are required to establish HTTPS connections with the Celona Orchestrator and the IPSEC channel with the Celona Edge are installed to the Indoor AP at the factory. If the certificates need to be updated or replaced, the process is automatically triggered and managed by the Celona Edge. The certificates conform to the industry-compliant X.509 standard. The IPSEC gateway is provisioned at the Celona AP 22 through the Celona Orchestrator. IKEv2 is used to establish the IPSEC tunnel between the Celona AP 22 and the Celona Edge.

Phase and time synchronization

Celona AP 22 supports Time Division Duplex (TDD) which has strict requirements for maintaining time and phase synchronization so that it does not interfere with neighboring

APs. The Celona AP 22s have a built-in, high-fidelity GPS chip that can establish location as well as maintain clock synchronization.

The AP's carrier frequency accuracy, time and phase drifts are disciplined by the onboard GPS clock. If the AP cannot obtain a GPS lock for any reason, Celona AP 22 synchronizes with a Precision Time Protocol (PTP) server to maintain time, phase, and frequency synchronization.

Data and voice connectivity

Mobile stations can access data, video, and voice applications over the enterprise IP network via the Celona Edge after the Celona AP 22 has its radio enabled. Note that the Celona AP 22 can simultaneously provide voice, video, and data sessions to mobile stations. Celona AP 22 automatically determines the capability of mobile stations before determining whether requested services can be accommodated.

Celona AP 22 and Celona Edge perform admission control for mobile stations and Celona Edge enforces authentication of the mobile station before accepting service requests and keep all control signals and user data encrypted.

Celona AP 22 employs sophisticated adaptive modulation and code rate control for adapting mobile station link according to the dynamic channel conditions seen on the air interface. It also employs effective power control to keep transmit powers from the mobile stations as low as practicable.

Power save mode

Celona AP 22 enables, and controls power save options on the mobile stations. When a mobile station has encountered a long lull in data volume, Celona AP 22 monitors traffic volume on each flow enabled at the mobile station.

When the traffic volume is zero for a duration of time, duration determined by the Celona AP 22 based on mobile capability as well as current loading in the system, Celona AP 22 enables Power Save mode on the mobile station. While in power save mode, the mobile station can turn off its receiver and transmitter functions for the most part except for essential functions. This increases the battery standby time on the mobile stations.

When the mobile station is in power save mode and if there is user data destined towards the mobile station, Celona Edge pages the mobile station indicating data arrival via the Celona AP 22 in order to awaken the station.

Radio access technology

Celona AP 22 implements an extensive set of 3GPP worldwide standards to provide advanced, 5th-generation packet radio service to mobile stations.

Supported frequency band

The Celona AP 22 is a 3GPP Release 15 compliant integrated 5G NR, operating within the 3300–4200 MHz spectrum band. AP 22 supports 2x2 MIMO (multiple-input, multiple-output), up to 256-QAM modulation and can be ceiling or wall mounted. Any Celona AP 22 within a Celona private 5G network is automatically assigned frequency and power levels by Celona’s unique Self Organizing Network (SON) software function, after the Celona Edge retrieves available frequency channels per AP from SAS, given each AP’s geolocation.

Frequency Band Support (SKUs)

AP22-48 3.55–3.7 GHz

AP22-78 3.3–3.8 GHz

AP22-77 3.8–4.2 GHz

Seamless session mobility

If there are multiple Celona AP 22s in the system all connecting to the same Celona Edge, the Celona AP 22s can enable seamless mobility for mobile stations. The source and target Celona AP 22s handle the transfer of contextual information corresponding to existing flows setup for the mobile station automatically.

Coverage area

The coverage area of each Celona AP 22 depends on several factors:

- Transmit power authorized by the Spectrum Manager
- Transmit power set on the Celona AP 22 by Celona Edge
- Number of other APs operating on the same frequency in the geographic area
- Proximity of other APs operating on a different frequency but in the same band
- Building type and material types used within the building
- Expected minimum for data rate at the edge of coverage

As a rule of thumb, at maximum transmit power, the Celona AP 22 should provide coverage between 10,000 and 25,000 square feet.

Transmit power

The Celona AP 22 can transmit at a maximum power of 24 dBm max per port plus a built-in omni with max 6 dBi antenna gain

Supported system bandwidth

The Celona AP 22 supports one sector, and the system bandwidths are supported are:

AP22-48: 20/40 MHz

AP22-78: 40/60/80/100 MHz

AP22-77: 40/60/80/100 MHz

Power Adapter/Injector Details (Warning: power socket for PoE injector should be grounded)

UL Listed - 56Vdc	1.07A/min
	0.535A + 0.535A/min

Troubleshooting

System LED is not blue:

- Ensure the AP 22 has a POE++ (802.11 bt) connection. POE (802.11 at) is not sufficient.
- Please check for loose connections between the PoE++ injector / PoE++ switch and the Celona AP 22.

Contacting Support

Celona support is available via support@celona.io.

Warranty

As part of an active Celona subscription, Celona AP 22 comes with a limited warranty that includes advanced replacement for RMA.

FCC Compliance Statement

The Celona AP22 meets FCC Part 15 requirements and is a Class A, AP designed to minimize interference in commercial environments. Improper use may cause interference to radio communications. The device meets applicable RF exposure limits and should be operated with a minimum distance of 20 cm between the AP and the body.

The Celona AP20/22 complies with Part 15 of the FCC Rules. Its operation is subject to the following two conditions: 1) The AP must not cause harmful interference, and 2) The AP must accept any interference received, including interference that may cause undesired operation.

Any changes or modifications not expressly approved by the party responsible for compliance could void the user's authority to operate the equipment. The AP has been tested and found to comply with the limits for a Class A digital device, as specified in Part 15 of the FCC Rules. These limits are designed to provide reasonable protection against harmful interference when the equipment is operated in a commercial environment. This equipment generates, uses, and can radiate radio frequency energy. If not installed and used in accordance with the instruction manual, it may cause harmful interference to radio communications. Operating this equipment in a residential area is likely to cause harmful interference. In such a case, the user will be required to correct the interference at their own expense.



© Copyright 2023 Celona Inc. All rights reserved.

hello@celona.io

900 E Hamilton Ave Suite 200,
Campbell, CA 95008, United States